

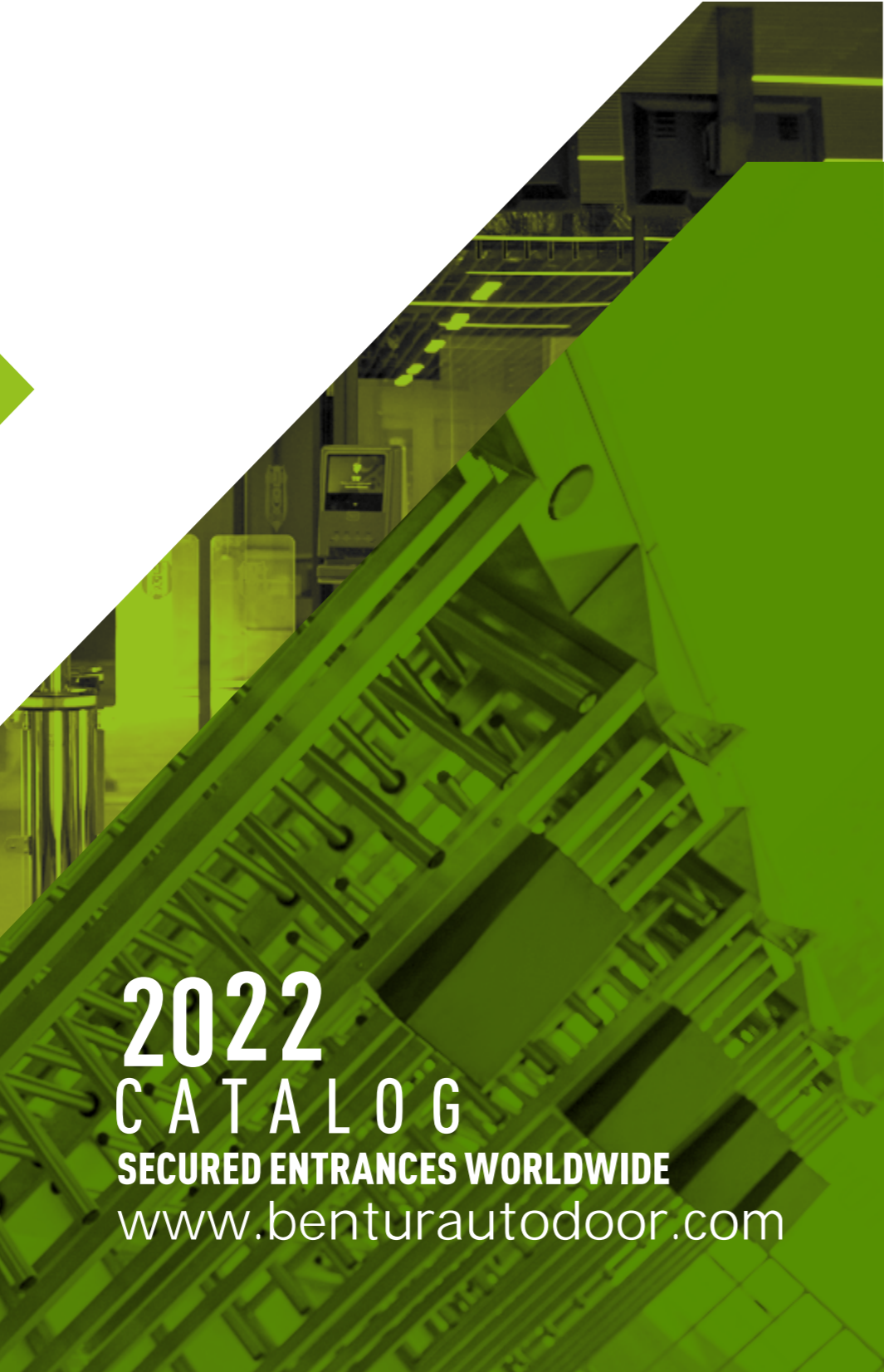

# BENTUR

AUTOMATIC DOOR SYSTEM



2022  
CATALOG  
SECURED ENTRANCES WORLDWIDE  
[www.benturautodoor.com](http://www.benturautodoor.com)

**BENTUR**  
AUTOMATIC DOOR SYSTEM

Phone Call: +90 216 540 16 63  
Whatsup : +90 553 170 50 26

Istanbul Office:  
Necip Fazıl Mahallesi Güney Sokak No:5 Kat:2 Yukari Dudullu - Istanbul



## SWG 700 SPEED GATE TURNSTILE

### Operation

Controlled or control-free entrance / exit in both directions.

### Chassis

AISI 304 quality stainless steel. Optional: Black stainless steel.

### Wing

With high glass, linear winged 10 mm tempered glass that can open in either direction. Optional: Smoke colored glass.

### Upper Table

10 mm black tempered glass.

### Functions

Operates bidirectionally and allows the passage of a single person only with its microprocessor control, electronic passage memory feature saves in memory card swipes that occur before a passage is completed and allows them to pass without closing the wings. Optional: 2 x RS232 and 1 x RS485 communication ports.

### Mechanism

Wings are operated by means of a servomotor. Precision motor movement with 16 bit microcontroller and encoder support, and motor-locking in the event of unauthorized pass.

### Sensors

14 reciprocal sensors in every turnstile.

### Emergency Mode

Turnstile switches to emergency mode upon the receipt of a signal from fire detection system and wings open in predefined direction.

### Safety Level Setting

With 4 security levels that can be defined as desired by the customer, turnstile is able to detect unauthorized passes and passes in the opposite direction and emits an audio or discreet warning.

### Indicator

Led lighting around the top plate and transition leds.

### Operating Voltage

100-230 VAC. 47-60 Hz

### Power Consumption

20W during passage, 8W during standby (For two wings).

### Operating Temperature

0° / +55°

### Passage Speed

~60 persons / minute.

### Wing Speed

1 sec. (Opening - Closing).

### Passage Width

55 cm

### Weight

~120 kg (Single wing)

### Security Level

Deterrent.

### Areas of Use

Suitable for indoor use.

### Accessories

Logo engraving. Sticker. Remote control unit. Stainless steel reader apparatus. Meter. Button control unit. Stainless steel reader leg. Stainless steel bottom plate.

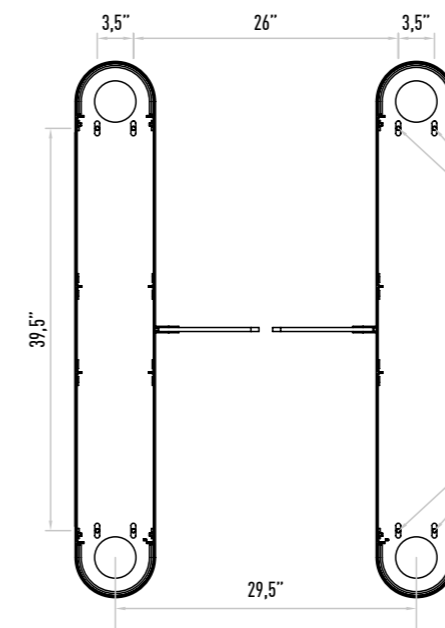
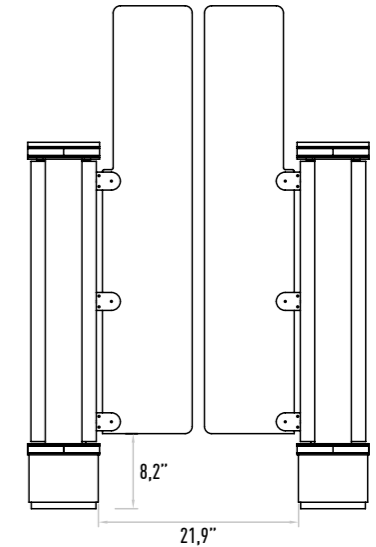
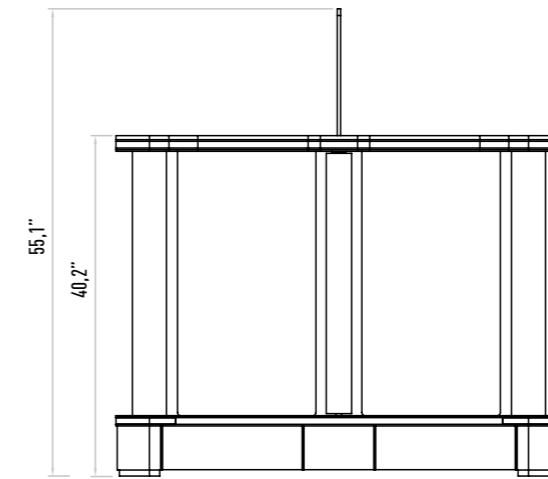

Ground Mounting Point M10

Cable Line Out Point

